

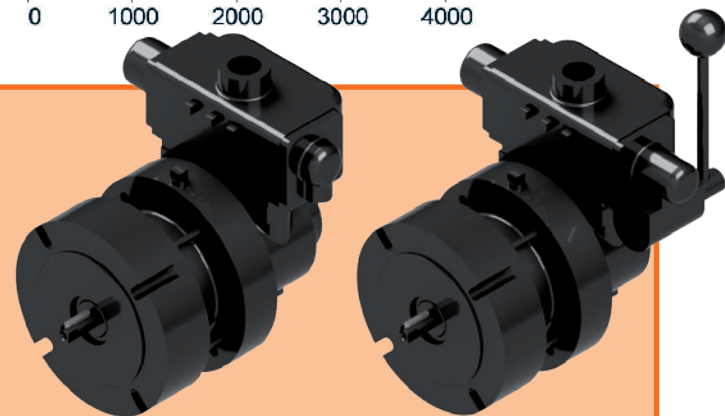

M250BN71H2/R2

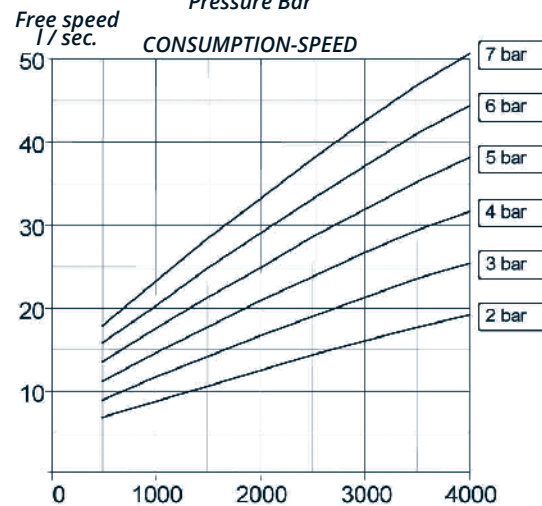
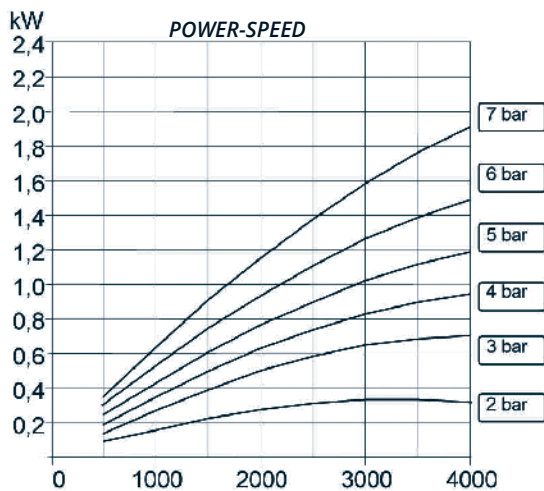
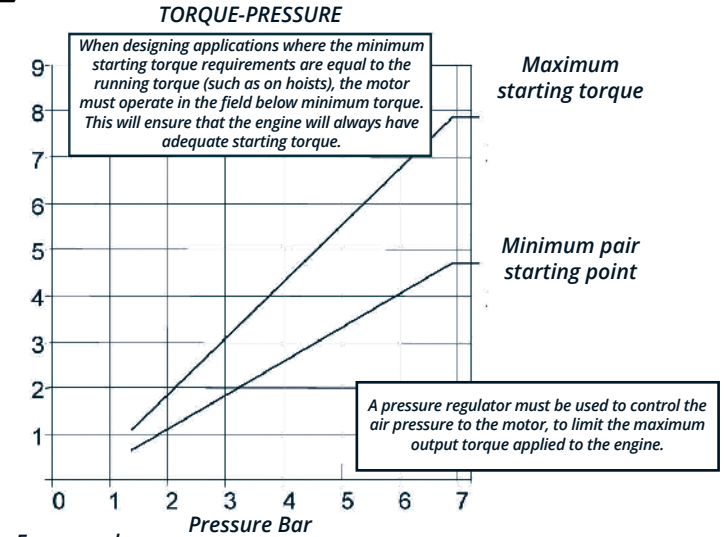
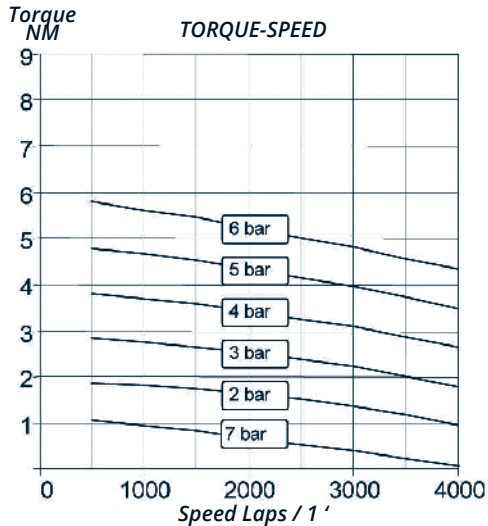

Silencer delivered with the motor.

Noise level: 84 dB

The motor is reversible.

Position: the motor can be used in any position.

Temperature range

from -20 ° C to +80 ° C (-4 ° F to +176 ° F).

FILTERING AND LUBRICATION

Filtering rate 64 micron or higher. Choose a lubricator suitable for the required flow rate. When first starting the motor , inject the oil into the inlet gate.

Lubricator continuous drop rate: 4-5 drops / minute

Lubricator intermittent drop rate: 9-12 drops / minute

Maximum continuous speed 4000 rpm

Maximum radial load on the motor shaft 170 N (40 lbf.).

Axial loads need to be kept to a minimum.